

# **User's and Service Guide**

## **Agilent Technologies 85055A Type-N 50 $\Omega$ Verification Kit**



**Agilent Part Number: 85055-90014**

**Printed in USA**

**Print Date: April 2007**

Supersedes: July 2005

© Copyright 1995, 2000, 2005, 2007 Agilent Technologies, Inc. All rights reserved.

---

## Documentation Warranty

THE MATERIAL CONTAINED IN THIS DOCUMENT IS PROVIDED "AS IS," AND IS SUBJECT TO BEING CHANGED, WITHOUT NOTICE, IN FUTURE EDITIONS. FURTHER, TO THE MAXIMUM EXTENT PERMITTED BY APPLICABLE LAW, AGILENT DISCLAIMS ALL WARRANTIES, EITHER EXPRESS OR IMPLIED WITH REGARD TO THIS MANUAL AND ANY INFORMATION CONTAINED HEREIN, INCLUDING BUT NOT LIMITED TO THE IMPLIED WARRANTIES OF MERCHANTABILITY AND FITNESS FOR A PARTICULAR PURPOSE. AGILENT SHALL NOT BE LIABLE FOR ERRORS OR FOR INCIDENTAL OR CONSEQUENTIAL DAMAGES IN CONNECTION WITH THE FURNISHING, USE, OR PERFORMANCE OF THIS DOCUMENT OR ANY INFORMATION CONTAINED HEREIN. SHOULD AGILENT AND THE USER HAVE A SEPARATE WRITTEN AGREEMENT WITH WARRANTY TERMS COVERING THE MATERIAL IN THIS DOCUMENT THAT CONFLICT WITH THESE TERMS, THE WARRANTY TERMS IN THE SEPARATE AGREEMENT WILL CONTROL.

---

## DFARS/Restricted Rights Notice

If software is for use in the performance of a U.S. Government prime contract or subcontract, Software is delivered and licensed as "Commercial computer software" as defined in DFAR 252.227-7014 (June 1995), or as a "commercial item" as defined in FAR 2.101(a) or as "Restricted computer software" as defined in FAR 52.227-19 (June 1987) or any equivalent agency regulation or contract clause. Use, duplication or disclosure of Software is subject to Agilent Technologies' standard commercial license terms, and non-DOD Departments and Agencies of the U.S. Government will receive no greater than Restricted Rights as defined in FAR 52.227-19(c)(1-2) (June 1987). U.S. Government users will receive no greater than Limited Rights as defined in FAR 52.227-14 (June 1987) or DFAR 252.227-7015 (b)(2) (November 1995), as applicable in any technical data.

---

## Printing Copies of Documentation from the Web

To print copies of documentation from the Web, download the PDF file from the Agilent web site:

- Go to [www.agilent.com](http://www.agilent.com).
- Enter the document's part number (located on the title page) in the Quick Search box.
- Click SEARCH.
- Click on the hyperlink for the document.
- When the PDF document is open, click the printer icon located in the tool bar.

---

# Contents

## 1. General Information

Verification Kit Overview . . . . .	1-2
Kit Contents . . . . .	1-2
Equipment Required but Not Supplied . . . . .	1-2
Incoming Inspection . . . . .	1-3
Recording the Device Serial Numbers . . . . .	1-4
Precision Slotless Connectors . . . . .	1-5
Clarifying the Terminology of a Connector Interface . . . . .	1-6
Preventive Maintenance . . . . .	1-6

## 2. Specifications

Environmental Requirements . . . . .	2-2
Temperature—What To Watch Out For . . . . .	2-2
Mechanical Characteristics . . . . .	2-3
Pin Depth . . . . .	2-3
Airline Mechanical Characteristics . . . . .	2-4
Electrical Specifications . . . . .	2-6

## 3. Duplicating Your Verification Data

Using a PC or Your Network Analyzer to Duplicate the Verification Data Disks . . . . .	3-2
Using an 8510C Network Analyzer . . . . .	3-3
Using an 8719, 8720, or 8722 Series Network Analyzer . . . . .	3-4
Using a PNA Series Network Analyzer . . . . .	3-5

## 4. Use, Maintenance, and Care of the Devices

Electrostatic Discharge . . . . .	4-2
Visual Inspection . . . . .	4-3
Look for Obvious Defects and Damage First . . . . .	4-3
What Causes Connector Wear? . . . . .	4-3
Inspect the Mating Plane Surfaces . . . . .	4-3
Inspect Female Connectors . . . . .	4-4
Cleaning Connectors . . . . .	4-4
Gaging Connectors . . . . .	4-6
Connector Gage Accuracy . . . . .	4-6
When to Gage Connectors . . . . .	4-6
Reading the Connector Gage . . . . .	4-7
Gaging Procedures . . . . .	4-8
Gaging Type-N Connectors . . . . .	4-8
Gaging the Airline . . . . .	4-10
Connections . . . . .	4-14
How to Make a Connection . . . . .	4-14
Preliminary Connection . . . . .	4-14
Final Connection Using a Torque Wrench . . . . .	4-14
Connecting the Airline . . . . .	4-16
How to Separate a Connection . . . . .	4-18
Handling and Storage . . . . .	4-18

## 5. Performance Verification

Introduction . . . . .	5-2
How Agilent Verifies the Devices in Your Kit . . . . .	5-2
Recertification . . . . .	5-3
How Often to Recertify. . . . .	5-3
Where to Send a Kit for Recertification . . . . .	5-3
<b>6. Troubleshooting</b>	
Troubleshooting Process . . . . .	6-2
Compatible Network Analyzers . . . . .	6-2
Where to Look for More Information . . . . .	6-4
Returning a Kit or Device to Agilent Technologies . . . . .	6-4
Contacting Agilent. . . . .	6-5
<b>7. Replaceable Parts</b>	
Introduction . . . . .	7-2

# **1 General Information**

## Verification Kit Overview

The Agilent 85055A 50 $\Omega$  type-N verification kit provides a set of standards with known characteristics, traceable to a reference (golden) standard in Agilent Technologies calibration lab. This set of standards is used to verify your measurement calibration and also to verify that your network analyzer system is operating within its specifications. The frequency range covered by the 85055A is from 300 kHz to 18 GHz.

The 85055A verification kit is intended to be used with the 85032F and 85054B 50 $\Omega$  type-N calibration kits and any of the following Agilent network analyzers:

- 8510 series
- 8719 series and 8720 series
- PNA series

### Kit Contents

The 85055A verification kit includes the following items:

- 20 dB attenuator
- 50 dB attenuator
- 25 $\Omega$  mismatch airline
- 50 $\Omega$  airline
- data disks that contain factory-measured verification data. Refer to [Table 7-1](#) for a list of the disks supplied.

---

**NOTE** A file containing the verification data for your kit is maintained for one year from the time of measurement. If you lose this data, contact Agilent Technologies. See [“Contacting Agilent” on page 6-5](#).

---

### Equipment Required but Not Supplied

Some items are required or recommended for successful operation of your kit, but are not supplied with the kit. Refer to [Table 7-2 on page 7-3](#) for a list of these items and for ordering information.

## Incoming Inspection

Verify that the shipment is complete by referring to [Table 7-1](#) and [Figure 7-1](#).

Check for damage. The foam-lined storage case provides protection during shipping. Verify that this case and its contents are not damaged.

If the case or any device appears damaged, or if the shipment is incomplete, contact Agilent Technologies. See [“Contacting Agilent” on page 6-5](#). Agilent will arrange for repair or replacement of incomplete or damaged shipments without waiting for a settlement from the transportation company. Refer to [“Returning a Kit or Device to Agilent Technologies” on page 6-4](#) for instructions.

---

## Recording the Device Serial Numbers

In addition to the kit serial number, the devices in this kit are individually serialized (serial numbers are labeled into the body of each device). Record these serial numbers in [Table 1-1](#). Recording the serial numbers will prevent confusing the devices in this kit with similar devices from other kits.

**Table 1-1 Serial Number Record for the 85055A**

Device	Serial Number
Verification kit	_____
20 dB attenuator	_____
50 dB attenuator	_____
50Ω airline	_____
25Ω mismatch airline	_____



## Precision Slotless Connectors

The female type-N connectors in this verification kit are metrology-grade, precision slotless connectors (PSC). A characteristic of metrology-grade connectors is direct traceability to national measurement standards through their well-defined mechanical dimensions.

Conventional female center conductors are slotted. When mated, the female center conductor is flared by the male pin. Because physical dimensions determine connector impedance, electrical characteristics of the female connector (and connection pair) are dependent upon the mechanical dimensions of the male pin. While connectors are used in pairs, their male and female halves are always specified separately as part of a standard, instrument, or device under test. Because of these facts, making precision measurements with the conventional slotted connector is very difficult, and establishing a direct traceability path to primary dimensional standards is nearly impossible.

The precision slotless connector was developed to eliminate these problems. All PSCs are female. A PSC incorporates a center conductor with a solid cylindrical shell that defines the outside diameter of the female center pin. Its outside diameter and, therefore, the impedance in its region does not change. The inner part provides an internal contact that flexes to accept the allowed range of male pin diameters.

The calibration of a network analyzer having a conventional slotted female connector on the test port remains valid only when the device under test and all calibration standards have identical male pin diameters. For this reason PSC test port adapters are supplied in most Agilent Technologies calibration kits.

### **Precision slotless connectors have the following characteristics:**

- There is no loss of traceable calibration on test ports when the male pin diameter of the connector on the device under test is different from the male pin diameter of the calibration standard.
- The female PSC and its mating male connector can be measured and specified separately as part of the device either is attached to.
- All female connectors can have a known, stable impedance based only on the diameters of their inner and outer conductors.
- Female calibration standards can be fully specified. Their specifications and traceability are unaffected by the diameter of the male mating pin.
- A fully traceable performance verification is made using a precision 50 $\Omega$  airline having a PSC.
- Measurement repeatability is enhanced due to non-changing connector characteristics with various pin diameters.

With PSCs on test ports and standards, the percentage of accuracy achieved when measuring at 50 dB return loss levels is comparable to using conventional slotted connectors measuring devices having only 30 dB return loss. This represents an accuracy improvement of about 10 times.

## Clarifying the Terminology of a Connector Interface

In this document and in the prompts of the PNA calibration wizard, the gender of cable connectors and adapters is referred to in terms of the center conductor. For example, a connector or device designated as 1.85 mm –f– has a 1.85 mm female center conductor.

**8510-series, 872x, and 875x ONLY:** In contrast, during a measurement calibration, the network analyzer softkey menus label a 1.85 mm calibration device with reference to the sex of the analyzer’s test port connector—not the calibration device connector. For example, the label `SHORT (F)` refers to the short that is to be connected to the female test port. This will be a male short from the calibration kit.

**Table 1-2 Clarifying the Sex of Connectors: Examples**

Terminology	Meaning
Short –f–	Female short (female center conductor)
Short (f)	Male short (male center conductor) to be connected to female port

A connector gage is referred to in terms of the connector that it measures. For instance, a male connector gage has a female connector on the gage so that it can measure male devices.

---

## Preventive Maintenance

The best techniques for maintaining the integrity of the devices in this kit include:

- routine visual inspection
- cleaning
- proper gaging
- proper connection techniques

All of these are described in [Chapter 4](#). Failure to detect and remove dirt or metallic particles on a mating plane surface can degrade repeatability and accuracy and can damage any connector mated to it. Improper connections, resulting from pin depth values being out of specification (see [Table 2-2 on page 2-4](#)), or from bad connection techniques, can also damage these devices.

## **2 Specifications**

---

## Environmental Requirements

---

**NOTE** Samples of this product have been type-tested in accordance with the Agilent Environmental Test Manual and verified to be robust against the environmental stresses of storage, transportation and end-use; those stresses include but are not limited to temperature, humidity, shock, vibration, altitude and power-line conditions. Test methods are aligned with IEC 60068-2 and levels are similar to MIL-PRF-28800F Class 3.

---

**Table 2-1 Environmental Requirements**

Parameter	Required Values/Ranges
Temperature	
Operating <sup>a</sup>	+20 °C to +26 °C
Storage	–40 °C to +71 °C
Error-corrected range <sup>b</sup>	±1 °C of measurement calibration temperature
Altitude	
Operating	< 4,500 meters (≈15,000 feet)
Storage	< 15,000 meters (≈50,000 feet)
Relative humidity	Type tested, 0% to 95% at 40 °C non–condensing

- a. The temperature range over which the calibration standards maintain conformance to their specifications.
- b. The allowable network analyzer ambient temperature drift during measurement calibration and during measurements when the network analyzer error correction is turned on. Also, the range over which the network analyzer maintains its specified performance while correction is turned on.

### Temperature—What To Watch Out For

Due to the small dimensions of the devices, electrical characteristics will change with temperature. Therefore, the operating temperature is a critical factor in their performance, and must be stable before use.

---

**IMPORTANT** Avoid unnecessary handling of the devices during use because your fingers are a heat source.

---

## Mechanical Characteristics

Mechanical characteristics such as center conductor protrusion and pin depth are *not warranted* performance specifications. They are, however, important supplemental characteristics related to electrical performance. Agilent Technologies verifies the mechanical characteristics of the devices in this kit with special gaging processes and electrical testing. This ensures that the device connectors do not exhibit any improper pin depth when the kit leaves the factory.

“Gaging Connectors” on page 4-6 explains how to use gages to determine if the kit devices have maintained their mechanical integrity. Refer to Table 2-2 on page 2-4 for typical and observed pin depth limits.

### Pin Depth

Pin depth is the distance the center conductor mating plane differs from being flush with the outer conductor mating plane. See Figure 2-1. Some coaxial connectors, such as 2.4 mm and 3.5 mm, are designed to have these planes nearly flush. Type-N connectors, however, are designed with a pin depth offset of approximately 5.26 mm (0.207 inch), not permitting these planes to be flush. The male center conductors are recessed by the offset value while the female center conductors compensate by protruding the same amount. This offset necessitates the redefining of pin depth with regard to protrusion and recession.

**Protrusion** refers to a male type-N connector center conductor having a pin depth value less than 5.26 mm (0.207 inch), or a female type-N connector center conductor having a pin depth value greater than 5.26 mm (0.207 inch).

**Recession** refers to a male type-N connector center conductor having a pin depth value greater than 5.26 mm (0.207 in), or a female type-N connector center conductor having a pin depth value less than 5.26 mm (0.207 inch).

**Figure 2-1 Connector Pin Depth**

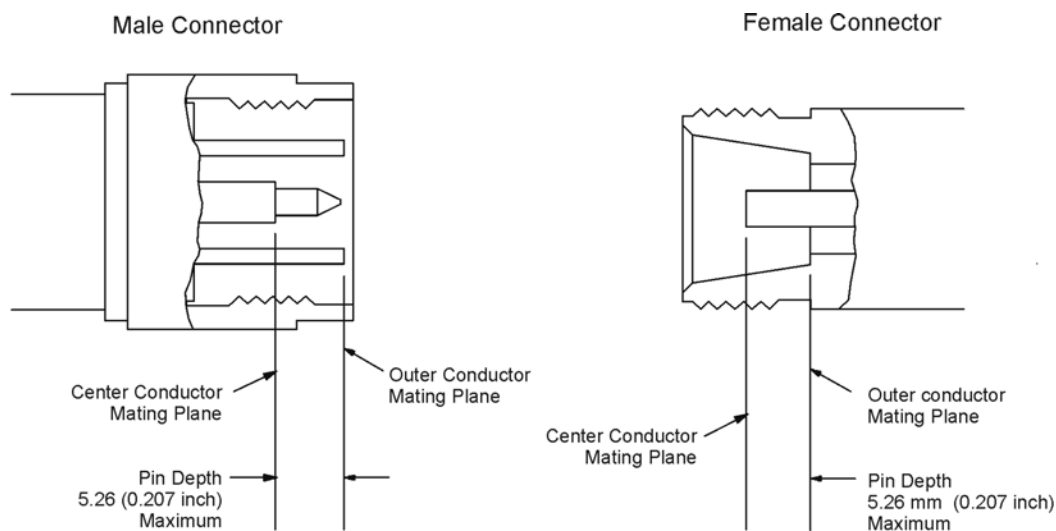

wf53b

---

**NOTE** The gages for measuring type-N connectors compensate for the designed offset of 5.26 mm (0.207 inch), therefore, protrusion and recession readings are in relation to a *zero* reference plane (as if the inner and outer conductor planes were intended to be flush).

---

**Table 2-2 Connector Pin Depths**

Connectors	Allowable Recession	
	millimeters	inches
Attenuators		
Male	0.0000 to +0.0076	0.000 to +0.003
Female	0.0000 to +0.0076	0.000 to +0.003
Airlines <sup>a</sup>	-0.0025 <sup>b</sup> to -0.0100	-0.0001 <sup>b</sup> to -0.0004

- a. The relationship between the length of the inner conductor and the length of the outer conductor determines the airline center conductor recession. Refer to “Gaging the Airline” on page 4-10.
- b. In this case, the center conductor is 0.0025 mm (0.0001) inch longer than the outer conductor.

## Airline Mechanical Characteristics

The dimensions of the airline outer conductor are shown in [Figure 2-2](#). This outer conductor is common to both airlines. Two conductors are provided with the kit.

The dimensions of the 50Ω airline and the 25Ω mismatch airline are shown in [Figure 2-3](#) and [Figure 2-4](#).

---

**CAUTION** The center and outer conductors of the airlines in this kit have been mechanically measured and matched. Do *not* use the center or outer conductors provided in this kit with a center or outer conductor from any other airline. Damage to the airline or attaching connector may result.

---

**Figure 2-2 Airline Outer Conductor**

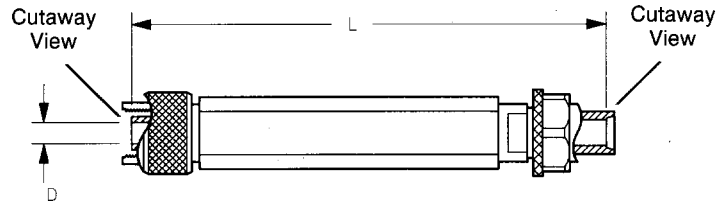

f22

Dimension	millimeters	inches
D	7.000 ±0.004	0.27560 ±0.00016
L	124.873 ±0.025	4.9163 ±0.0010

**Figure 2-3 50 Ω Airline Center conductor**



ohm50

Dimension	millimeters	inches
d	3.0400 ±0.0025	0.1197 ±0.0001
ΔL	+0.0025 to 0.0100	+0.0001 to 0.0004

**Figure 2-4 25 Ω Mismatch Airline Center Conductor**

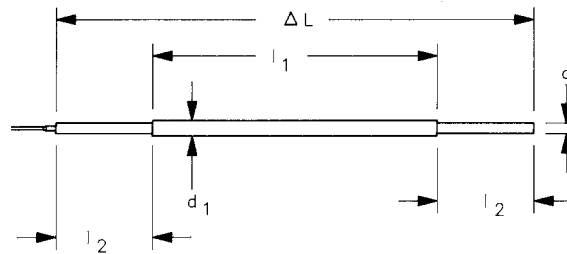

mis

Dimension	millimeters	inches
d	3.010 ±0.008	0.1197 ±0.0003
d <sub>1</sub>	4.613 ±0.005	0.1816 ±0.0002
l <sub>1</sub>	74.930 ±0.019	2.95000 ±0.00075
l <sub>2</sub>	25.002 ±0.050	0.9843 ±0.0020
ΔL	+0.0025 to -0.0100	+0.0001 to -0.0004

## Electrical Specifications

At the factory, each verification device is electrically characterized on a network analyzer measurement system. These factory measurements are traceable to the National Institute of Standards and Technology (NIST) through mechanical and electrical paths (for more information on traceability, contact your nearest Agilent Technologies office. Refer to [“Contacting Agilent” on page 6-5](#)).

The factory-measured data for each device is supplied in print and on disk with your kit.



## **3 Duplicating Your Verification Data**

## **Using a PC or Your Network Analyzer to Duplicate the Verification Data Disks**

A backup copy of each verification data disk should be made immediately upon receipt of the verification kit. You may be able to use a personal computer (PC) to duplicate each disk. However, if the disk has LIF formatting, the PC will not be able to read it. If the PC is unable to read the disk, follow the instructions in this chapter to duplicate the disk using your network analyzer.

## Using an 8510C Network Analyzer

1. Initialize a blank disk:
  - a. Insert a blank disk in the 85101 disk drive and press **[TAPE/DISC]**.
  - b. Select **STORAGE IS INTERNAL, SETUP DISC, INITIALIZE DISC, YES**.
2. Insert the *original* data disk (it came in your verification kit) in the 85101 disk drive.
3. Press **[TAPE/DISC]** and select **LOAD, MEMORY ALL**. After you note the file numbers that have an asterisk next to them select **FILE 1**.
4. When file 1 is through loading, remove the *original* disk and insert the blank, initialized disk in the disk drive.
5. Duplicate the S-Parameters:
  - a. Press **[TAPE/DISC]** and select **STORE, MEMORY ALL, FILE 1**.
  - b. Repeat steps 2 through 5a, substituting the next file number with an asterisk (noted in step 3) for **FILE 1** until all the files with an asterisk are copied on the new disk.
6. Duplicate the uncertainty limits:
  - a. Insert the *original* data disk in the disk drive.
  - b. Press **[LOAD]** and select **LOAD MEMORY 1-8**. Note the memory locations that have an asterisk next to them and select **1**.
  - c. Note the file numbers that have an asterisk next to them and select **FILE 1**.
  - d. When file 1 memory location 1 is through loading, remove the *original* disk and insert the blank, initialized disk in the disk drive.
  - e. Press **[TAPE/DISC]** and select **STORE, MEMORY 1-8, 1, FILE 1**.
  - f. Repeat steps 6a through 6e substituting the appropriate memory locations (noted in step 6b) and files (noted in step 6c) until all files in all memory locations are copied on the new disk.
7. Verify the new disk has duplicated properly by pressing **[TAPE/DISC]** and selecting **DIRECTORY**. The screen displays four **MEMORY ALL** files and four **MEMORY 1-8** files.
8. Remove the data disk from the disk drive.
9. Write-protect the disk and label it.

## Using an 8719, 8720, or 8722 Series Network Analyzer

1. Write-protect the master disk. To do this slide the tab at the bottom edge of the disk so that the small square is open; you should be able to see through the square.
2. Write-enable the blank disk. To do this, slide the tab at the bottom edge of the disk so that the small square is filled; you should *not* be able to see through the square.
3. Press **[PRESET]** on the analyzer.
4. Insert the blank disk in drive 0.
5. Insert the master disk in drive 1.
6. Press the following keys on the analyzer to initialize the blank disk:  
**[LOCAL], SYSTEM CONTROLLER.** The analyzer is now controlling the disk drive.  
**DISK, UNIT NUMBER, [0], [x1]** to select the blank disk.  
**[SAVE], STORE TO DISK, DEFINE STORE, INITIALIZE DISK, YES.** The blank disk is now initialized.
7. Press the following keys to get the first set of files from the master disk:  
**[LOCAL], DISK UNIT NUMBER, [1], [x1]**  
**[RECALL], LOAD FROM DISK, READ FILE TITLES.** The first set of file titles is now displayed beside the softkeys.
8. Press the following keys to load the first file into the analyzer:  
**[LOCAL], DISK UNIT NUMBER, [1], [x1]**  
**[RECALL], LOAD FROM DISK**  
**LOAD (filename)**
9. Press the following keys to store the first file onto the blank disk:  
**[LOCAL], DISK UNIT NUMBER, [0], [x1]**  
**[SAVE], STORE TO DISK**  
**STORE (filename)**
10. This sequence has transferred the first file from the master disk to the blank disk. Repeat steps 7 and 8 to transfer the other titles shown on the softkey labels.
11. Repeat steps 6, 7, and 8 until all sets of files have been transferred.

## Using a PNA Series Network Analyzer

The disk supplied for use with the PNA series analyzers is formatted using MS-DOS® and, therefore, can be duplicated on a personal computer (PC).<sup>1</sup>

---

1. MS-DOS is a U.S. registered trademark of Microsoft Corporation.

Duplicating Your Verification Data  
**Using a PNA Series Network Analyzer**

## **4 Use, Maintenance, and Care of the Devices**

## Electrostatic Discharge

Protection against ESD (electrostatic discharge) is essential while connecting, inspecting, or cleaning connectors attached to a static-sensitive circuit (such as those found in test sets).

Static electricity can build up on your body and can easily damage sensitive internal circuit elements when discharged. Static discharges too small to be felt can cause permanent damage. Devices such as calibration components and devices under test (DUTs), can also carry an electrostatic charge. To prevent damage to the test set, components, and devices:

- *always* wear a grounded wrist strap having a 1 M $\Omega$  resistor in series with it when handling components and devices or when making connections to the test set.
- *always* use a grounded, conductive table mat while making connections.
- *always* wear a heel strap when working in an area with a conductive floor. If you are uncertain about the conductivity of your floor, wear a heel strap.
- *always* ground yourself before you clean, inspect, or make a connection to a static-sensitive device or test port. You can, for example, grasp the grounded outer shell of the test port or cable connector briefly.
- *always* ground the center conductor of a test cable before making a connection to the analyzer test port or other static-sensitive device. This can be done as follows:
  1. Connect a short (from your calibration kit) to one end of the cable to short the center conductor to the outer conductor.
  2. While wearing a grounded wrist strap, grasp the outer shell of the cable connector.
  3. Connect the other end of the cable to the test port.
  4. Remove the short from the cable.

Figure 4-1 shows a typical ESD protection setup using a grounded mat and wrist strap. For parts numbers of ESD protection supplies, refer to [Table 7-2 on page 7-3](#).

**Figure 4-1 ESD Protection Setup**

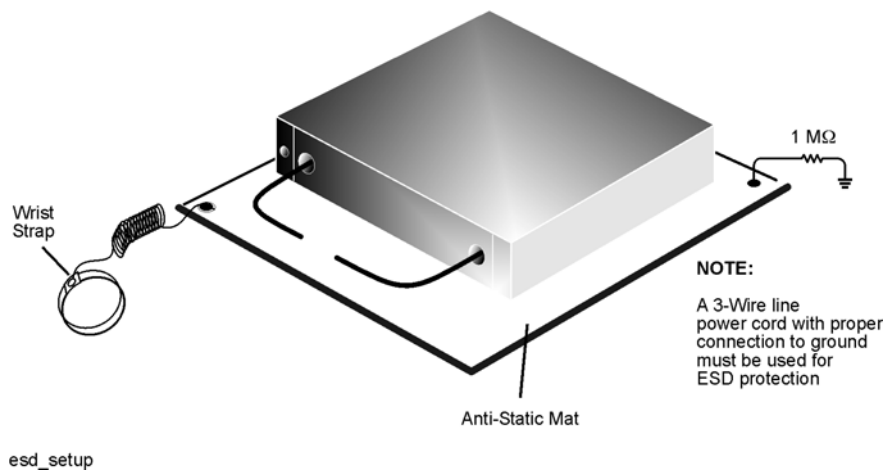



---

## Visual Inspection

Visual inspection and, if necessary, cleaning should be done every time a connection is made. Metal particles from the connector threads may fall into the connector when it is disconnected.

---

**CAUTION** Devices with damaged connectors should be immediately discarded or clearly marked and set aside for repair. A damaged device will in turn damage any good connector to which it is attached. Determine the cause of the damage before connecting a new, undamaged connector in the same configuration.

---

In some cases, magnification is necessary to see damage to a connector; a magnifying device with a magnification of  $\geq 10\times$  is recommended. However, not all defects that are visible only under magnification will affect the electrical performance of the connector. Use the following guidelines when evaluating the integrity of a connector.

### Look for Obvious Defects and Damage First

Examine the connectors first for obvious defects or damage: badly worn plating on the connector interface, deformed threads or bent, broken, or misaligned center conductors. Connector nuts should move smoothly and be free of burrs, loose metal particles, and rough spots.

### What Causes Connector Wear?

Connector wear is caused by connecting and disconnecting the devices. The more use a connector gets, the faster it wears and degrades. The wear is greatly accelerated when connectors are not kept clean, or are not connected properly.

Connector wear eventually degrades performance of the device. Calibration devices should have a long life if their use is on the order of a few times per week. Replace devices with worn connectors.

The test port connectors on the network analyzer test set may have many connections each day, and are therefore more subject to wear. It is recommended that an adapter be used as a test port saver to minimize the wear on the test set's test port connectors.

### Inspect the Mating Plane Surfaces

Flat contact between the connectors at all points on their mating plane surfaces is required for a good connection. See [Figure 2-1 on page 2-3](#). Look especially for deep scratches or dents, and for dirt and metal particles on the connector mating plane surfaces. Also look for signs of damage due to excessive or uneven wear or misalignment.

Light burnishing of the mating plane surfaces is normal, and is evident as light scratches or shallow circular marks distributed more or less uniformly over the mating plane surface. Other small defects and cosmetic imperfections are also normal. None of these affect electrical or mechanical performance. If a connector shows deep scratches or dents, particles clinging to the mating plane surfaces, or uneven wear, clean and inspect it again.

## Inspect Female Connectors

Inspect the contact fingers in the female center conductor carefully. These can be bent or broken, and damage to them is not always easy to see. A connector with damaged contact fingers will not make good electrical contact and must be replaced.

---

**NOTE** This is particularly important when mating nonprecision to precision devices.

---

The female connectors in this calibration kit are metrology-grade, precision slotless connectors (PSC). Precision slotless female connectors are used to improve accuracy. With PSCs on test ports and standards, the accuracy achieved when measuring at 50 dB return loss levels is comparable to using conventional slotted connectors measuring devices having only 30 dB return loss. This represents an accuracy improvement of about 10 times.

Conventional female center conductors are slotted and, when mated, are flared by the male pin. Because physical dimensions determine connector impedance, this change in physical dimension affects electrical performance, making it very difficult to perform precision measurements with conventional slotted female connectors.

The precision slotless connector was developed to eliminate this problem. The PSC has a center conductor with a solid cylindrical shell, the outside diameter of which does not change when mated. Instead, this center conductor has an internal contact that flexes to accept the male pin.

---

## Cleaning Connectors

### 1. Use Compressed Air or Nitrogen

Clean connectors are essential for ensuring the integrity of RF and microwave coaxial connections.

---

**WARNING** Always use protective eyewear when using compressed air or nitrogen.

---

Use compressed air (or nitrogen) to loosen particles on the connector mating plane surfaces.

You can use any source of clean, dry, low-pressure compressed air or nitrogen that has an effective oil-vapor filter and liquid condensation trap placed just before the outlet hose.

Ground the hose nozzle to prevent electrostatic discharge, and set the air pressure to less than 414 kPa (60 psi) to control the velocity of the air stream. High-velocity streams of compressed air can cause electrostatic effects when directed into a connector. These electrostatic effects can damage the device. Refer to [“Electrostatic Discharge” on page 4-2](#) for additional information.

## 2. Clean the Connector Threads

---

**WARNING**     **Keep isopropyl alcohol away from heat, sparks, and flame. Store in a tightly closed container. It is extremely flammable. In case of fire, use alcohol foam, dry chemical, or carbon dioxide; water may be ineffective.**

**Use isopropyl alcohol with adequate ventilation and avoid contact with eyes, skin, and clothing. It causes skin irritation, may cause eye damage, and is harmful if swallowed or inhaled. It may be harmful if absorbed through the skin. Wash thoroughly after handling.**

**In case of spill, soak up with sand or earth. Flush spill area with water.**

**Dispose of isopropyl alcohol in accordance with all applicable federal, state, and local environmental regulations.**

---

Use a lint-free swab or cleaning cloth moistened with isopropyl alcohol to remove any dirt or stubborn contaminants on a connector that cannot be removed with compressed air or nitrogen. Refer to [Table 7-2 on page 7-3](#) for a part number for cleaning swabs.

- a. Apply a small amount of isopropyl alcohol to a lint-free cleaning swab.
- b. Clean the connector threads.
- c. Let the alcohol evaporate, then blow the threads dry with a gentle stream of clean, low-pressure compressed air or nitrogen. Always completely dry a connector before you reassemble or use it.

## 3. Clean the Mating Plane Surfaces

- a. Apply a small amount of isopropyl alcohol to a lint-free cleaning swab.
- b. Clean the center and outer conductor mating plane surfaces. Refer to [Figure 2-1 on page 2-3](#). When cleaning a female connector, avoid snagging the swab on the center conductor contact fingers by using short strokes.
- c. Let the alcohol evaporate, then blow the connector dry with a gentle stream of clean, low-pressure compressed air or nitrogen. Always completely dry a connector before you reassemble or use it.

## 4. Inspect

Inspect the connector to make sure that no particles or residue remain. Refer to [“Visual Inspection” on page 4-3](#).

## Gaging Connectors

The gages available from Agilent Technologies are intended for preventive maintenance and troubleshooting purposes only. They are effective in detecting excessive center conductor protrusion or recession, and conductor damage on DUTs, test accessories, and the calibration kit devices. *Do not use the gages for precise pin depth measurements.*

### Connector Gage Accuracy

The connector gages are only capable of performing coarse measurements. They do not provide the degree of accuracy necessary to precisely measure the pin depth of the kit devices. This is partially due to the repeatability uncertainties that are associated with the measurement. Only the factory—through special gaging processes and electrical testing—can accurately verify the mechanical characteristics of the devices.

With proper technique, the gages are useful in detecting gross pin depth errors on device connectors. To achieve maximum accuracy, random errors must be reduced by taking the average of at least three measurements having different gage orientations on the connector. Even then, the resultant average can be in error by as much as  $\pm\pm\pm\pm 0.0001$  inch due to systematic (biasing) errors usually resulting from worn gages and gage masters. As the gages undergo more use, the systematic errors can become more significant in the accuracy of the measurement.

### When to Gage Connectors

Gage a connector at the following times:

- Prior to using a device for the first time: record the pin depth measurement so that it can be compared with future readings. This serves as a good troubleshooting tool when you suspect damage may have occurred to the device.

---

**NOTE** When measuring pin depth, the measured value (resultant average of three or more measurements) contains measurement uncertainty and is not necessarily the true value. Always compare the measured value with the observed pin depth limits (which account for measurement uncertainties) in [Table 2-2 on page 2-4](#) to evaluate the condition of device connectors.

---

- If either visual inspection or electrical performance suggests that the connector interface may be out of typical range (due to wear or damage, for example).
- If a verification device is used by someone else or on another system or piece of equipment.
- Initially after every 100 connections, and after that as often as experience indicates.

## Reading the Connector Gage

The gage dial is divided into increments of 0.0001 inch and major divisions of 0.001 inch (see [Figure 4-2](#)). For each revolution of the large dial, the smaller dial indicates a change of 0.01 inch. Use the small dial as the indicator of multiples of 0.01 inch. In most connector measuring applications, this value will be zero.

When making a measurement, the gage dial indicator will travel in one of two directions. If the center conductor is recessed from the *zero* reference plane, the indicator will move counterclockwise to indicate the amount of **recession**, which is read as a negative value. If the center conductor protrudes, the indicator will move clockwise to indicate the amount of **protrusion**, which is read as a positive value. Refer to [“Pin Depth” on page 2-3](#) for definitions of protrusion and recession.

**Figure 4-2** Reading the Connector Gage

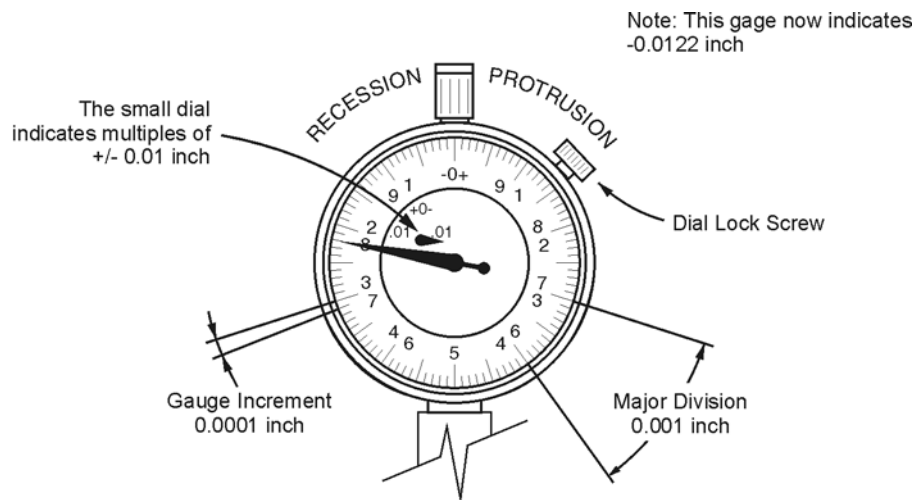

wj57f

## Gaging Procedures

### Gaging Type-N Connectors

---

**NOTE** Always hold a connector gage by the gage barrel, below the dial indicator. This gives the best stability, and improves measurement accuracy.

---

1. Select the proper gage for your connector. Refer to [Table 7-2 on page 7-3](#).
2. Inspect and clean the gage, gage master, and device to be gaged. Refer to “[Visual Inspection](#)” and “[Cleaning Connectors](#)” earlier in this chapter.
3. Zero the connector gage (refer to [Figure 4-3](#)):
  - a. While holding the gage by the barrel, and without turning the gage or the gage master, connect the gage to the gage master by interconnecting the male and female connectors. Connect the nut finger tight. Do not overtighten.
  - b. Using an open-end wrench to keep the device body from rotating, use the torque wrench recommended for use with this kit to tighten the connecting nut to the specified torque. Refer to “[Final Connection Using a Torque Wrench](#)” on [page 4-14](#) for more information.
  - c. Loosen the dial lock screw on the gage and rotate the gage dial so that the pointer corresponds to the correction value noted on the gage master. Do not adjust the gage dial to zero, unless the correction value on the gage master is zero.
  - d. Tighten the dial lock screw and remove the gage master.
  - e. Attach and torque the gage master to the gage once again to verify that the setting is repeatable. Remove the gage master.
4. Gage the device connector (refer to [Figure 4-3](#)):
  - a. While holding the gage by the barrel, and without turning the gage or the device, connect the gage to the device by interconnecting the male and female connectors. Connect the nut finger-tight. Do not overtighten.
  - b. Using an open-end wrench to keep the device body from rotating, use the torque wrench recommended for use with this kit to tighten the connecting nut to the specified torque. Refer to “[Final Connection Using a Torque Wrench](#)” on [page 4-14](#) for more information.
  - c. Gently tap the barrel of the gage with your finger to settle the gage reading.
  - d. Read the gage indicator dial. If the needle has moved clockwise, the center conductor is *protruding* by an amount indicated by the black numbers. If the needle has moved counterclockwise, the center conductor is *recessed* by an amount indicated by the red numbers.

For maximum accuracy, measure the connector a minimum of three times and take an average of the readings. After each measurement, rotate the gage a quarter-turn to reduce measurement variations that result from the gage or the connector face not being exactly perpendicular to the center axis.
  - e. Compare the average reading with the specifications listed in [Table 2-2 on page 2-4](#).
  - f. Without turning either the gage or the device, remove the device from the gage.

### Figure 4-3 Gaging Type-N Connectors

**NOTE:** Although male devices are shown in this illustration, the procedure is essentially the same for the female devices.

#### Zero the Connector Gage

- Connect the gage to the gage master.
- Torque the connecting nut.
- Loosen the dial lock screw.
- Adjust the gage to the correction value noted on the gage master.
- Tighten the dial lock screw.
- Remove the gage master.

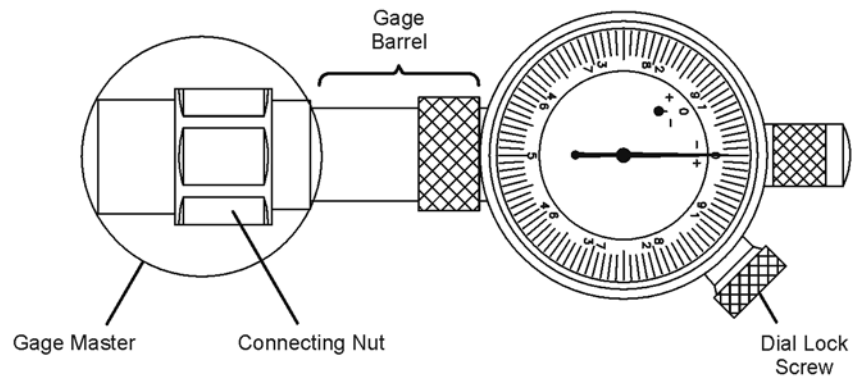

#### Gage the Device Connector

- Connect the gage to the device being measured.
- Torque the connecting nut.
- Gently tap the gage barrel to settle the reading.
- Read recession or protrusion from the gage.
- Remove the device.
- Repeat two additional times and average the three readings.

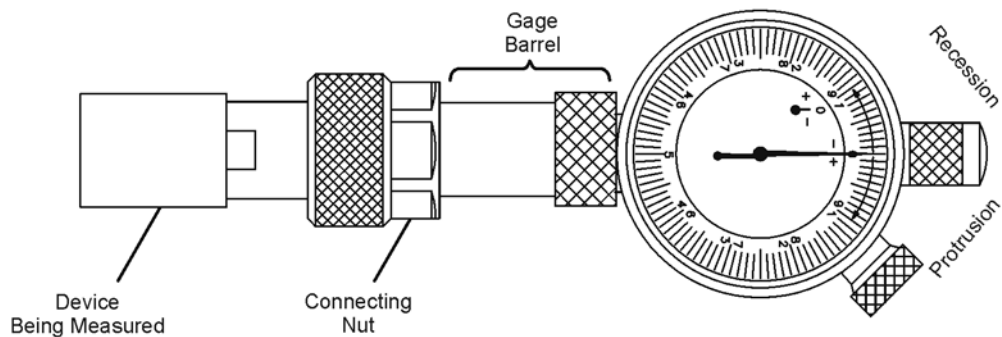

wj55f

## Gaging the Airline

The airlines in this kit are measured and matched for length at the factory using special fixtures and gages. Because the gages supplied in the calibration kits do not have the accuracy of the factory gages, use the following procedure for very general results only. Perform this procedure whenever you suspect that a center conductor has been switched with another airline or that a device has been damaged.

---

**NOTE** Always hold a connector gage by the gage barrel, below the dial indicator. This gives the best stability, and improves measurement accuracy.

---

1. Select a male connector gage and male short for this procedure. Refer to [Table 7-2 on page 7-3](#) for part numbers.
2. Inspect and clean the mating surfaces and connector threads of the short, airline, and gage. Refer to [“Visual Inspection”](#) and [“Cleaning Connectors”](#) earlier in this chapter.
3. Zero the connector gage (refer to [Figure 4-4](#)):
  - a. While holding the gage by the barrel and without turning the gage or the short, connect the gage to the short by interconnecting the male and female connectors. Connect the nut finger tight. Do not overtighten.
  - b. Using an open-end wrench to keep the device body from rotating, use the torque wrench recommended for use with this kit to tighten the connecting nut to the specified torque. Refer to [“Final Connection Using a Torque Wrench”](#) on page 4-14 for additional information.
  - c. As you watch the gage pointer, gently tap the barrel of the gage to settle the reading.
  - d. The gage pointer should line up exactly with the zero mark on the gage. If not, loosen the dial lock screw on the gage and rotate the gage dial so that the pointer is aligned with the zero mark. Tighten the dial lock screw.
  - e. Without turning the short or the gage, remove the short from the gage. Refer to [“How to Separate a Connection”](#) on page 4-18.

**Figure 4-4 Zeroing the Connector Gage Using the Short**

### Zero the Connector Gage

- Connect the gage to the short.
- Torque the connecting nut.
- Loosen the dial lock screw.
- Adjust the gage to the correction value noted on the gage master.
- Tighten the dial lock screw.
- Remove the short.

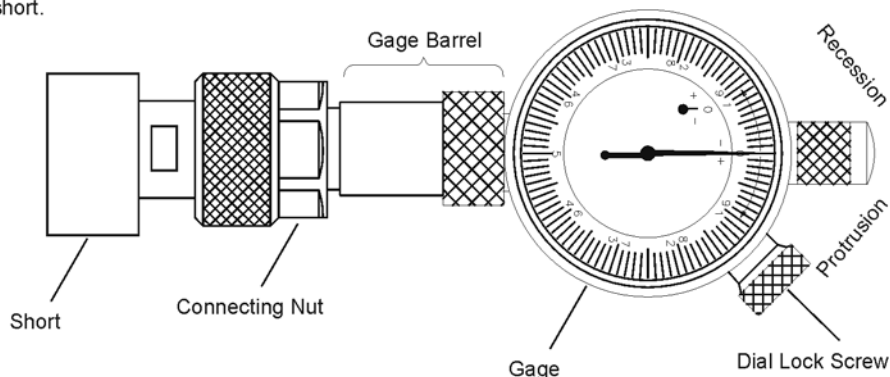

f33



4. Assemble the airline and center conductor (refer to [Figure 4-5](#)):

---

**CAUTION**      Wear gloves while performing the following steps. You will be touching the exposed center conductor of the airline. Do not transfer oil or dirt from your fingers to the center conductor. See [“Handling and Storage” on page 4-18](#).

---

- a. Remove the center conductor from its plastic case. Make sure you select the correct center conductor for the airline you are connecting. Refer to [Figure 2-3](#) and [Figure 2-4 on page 2-5](#) for illustrations of both center conductors.
- b. Remove the protective end cap from the female end (the end without the connecting nut) of the outer conductor.
- c. Leave the protective end cap on the male end of the airline to prevent the center conductor from falling out of the outer conductor.
- d. Insert the center conductor into the outer conductor so that the female end of the center conductor is toward the female end of the outer conductor (the end without the connector nut). Refer to [Figure 4-5](#).

**Figure 4-5 Assembling the Airline and Center Conductor**

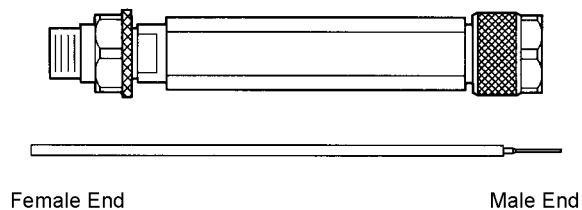

f41

5. Attach the short:

- a. Without turning the airline or the short, connect the airline to the short by interconnecting the male and female connectors. Connect the nut finger tight. Do not overtighten.
- b. Using an open-end wrench to keep the device body from rotating, use the torque wrench recommended for use with this kit to tighten the connecting nut to the specified torque. Refer to [“Final Connection Using a Torque Wrench” on page 4-14](#) for additional information.
- c. Remove the protective end cap from the male end of the airline.

---

**NOTE**      Do not allow either the center or outer conductor of the airline to come in contact with a metal or harder surface. The soft gold plating can be displaced, changing the pin depth and thus the performance of the airline.

---

- d. Carefully press the male end of the center conductor lightly against a firm flat object to seat the center conductor into the short.

6. Gage the airline (refer to [Figure 4-6](#)):
  - a. While holding the gage by the barrel, and without turning the gage or the airline, connect the gage to the airline by interconnecting the male and female connectors. Connect the nut finger tight. Do not overtighten.
  - b. Using an open-end wrench to keep the device body from rotating, use the torque wrench recommended for use with this kit to tighten the connecting nut to the specified torque. Refer to [“Final Connection Using a Torque Wrench”](#) on page 4-14 for additional information.
  - c. Gently tap the barrel of the gage with your finger to settle the gage reading.

**Figure 4-6 Gaging the Airline**

**Gage the Airline**

- Connect the gage to the airline (with the short attached).
- Torque the connecting nut.
- Gently tap the gage barrel to settle the reading.
- Read recession or protrusion from the gage.
- Remove the airline.
- Repeat two additional times and average the three readings.

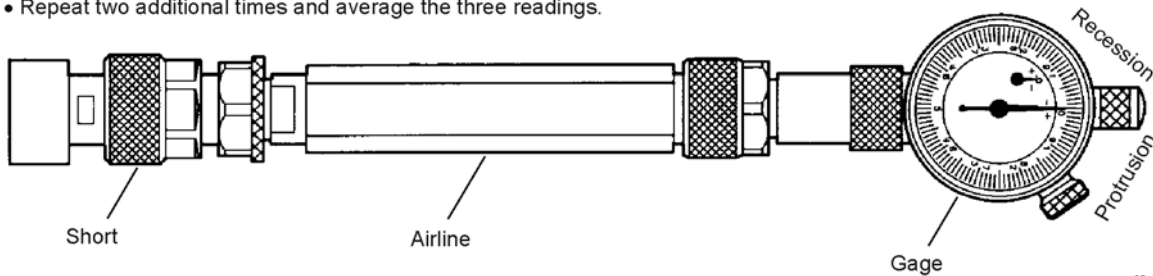

- d. Wait approximately 5 minutes for the temperature to stabilize. Do not touch the airline, short, or gage during this time as your body temperature will affect the temperature of the devices.

The gage reading should be within the pin depth specifications listed in [Table 2-2 on page 2-4](#). Remember, the gage is intended for coarse measurements only and has an accuracy of  $\pm 0.0001$  in.

7. Disconnect the short and gage from the airline:

---

**NOTE** If the airline center conductor does not disengage from the device center conductor, gently pull the center conductors apart and then push the airline center conductor back inside the outer conductor of the airline.

---

- a. Without turning the airline or the gage, remove the gage from the airline. Refer to [“How to Separate a Connection”](#) on page 4-18.
- b. Replace the protective end cap on the airline to prevent the center conductor from sliding out of the outer conductor.
- c. Without turning the airline or the short, remove the short from the airline. Refer to [“How to Separate a Connection”](#) on page 4-18.

- d. If you will not be using the airline again immediately, slide the center conductor out of the outer conductor and store the center conductor in the plastic case provided.
- e. Replace the other protective end cap on the outer conductor and store the center and outer conductors in the foam lined storage case.

---

## Connections

Good connections require a skilled operator. *The most common cause of measurement error is bad connections.* The following procedures illustrate how to make good connections.

### How to Make a Connection

#### Preliminary Connection

1. Ground yourself and all devices. Wear a grounded wrist strap and work on a grounded, conductive table mat. Refer to [“Electrostatic Discharge” on page 4-2](#) for ESD precautions.
2. Visually inspect the connectors. Refer to [“Visual Inspection” on page 4-3](#).
3. If necessary, clean the connectors. Refer to [“Cleaning Connectors” on page 4-4](#).
4. Use a connector gage to verify that all center conductors are within the pin depth values listed in [Table 2-2 on page 2-4](#). Refer to [“Gaging Connectors” on page 4-6](#).
5. Carefully align the connectors. The male connector center pin must slip concentrically into the contact finger of the female connector.
6. Push the connectors straight together and tighten the connector nut finger tight.

---

**CAUTION** Do not turn the device body. Turn only the connector nut. Damage to the center conductor can occur if the device body is rotated.

---

Do not twist or screw the connectors together. As the center conductors mate, there is usually a slight resistance.

7. The preliminary connection is tight enough when the mating plane surfaces make uniform, light contact. Do not overtighten this connection.

A connection in which the outer conductors make gentle contact at all points on both mating surfaces is sufficient. Very light finger pressure is enough to accomplish this.

8. Make sure the connectors are properly supported. Relieve any side pressure on the connection from long or heavy devices or cables.

#### Final Connection Using a Torque Wrench

Use a torque wrench to make a final connection. [Table 4-1](#) provides information about the torque wrench recommended for use with the calibration kit. A torque wrench is not included in the calibration kit. Refer to [Table 7-2 on page 7-3](#) for part number and ordering information.

**Table 4-1 Torque Wrench Information**

Connector Type	Torque Setting	Torque Tolerance
Type-N	135 N-cm (12 in-lb)	±13.5 N-cm (±1.2 in-lb)

Using a torque wrench guarantees that the connection is not too tight, preventing possible connector damage. It also guarantees that all connections are equally tight each time.

Prevent the rotation of anything other than the connector nut that you are tightening. It may be possible to do this by hand if one of the connectors is fixed (as on a test port). However, it is recommended that you use an open-end wrench to keep the body of the device from turning.

1. Position both wrenches within 90 degrees of each other before applying force. See [Figure 4-7](#). Wrenches opposing each other (greater than 90 degrees apart) will cause a lifting action which can misalign and stress the connections of the devices involved. This is especially true when several devices are connected together.

**Figure 4-7 Wrench Positions**

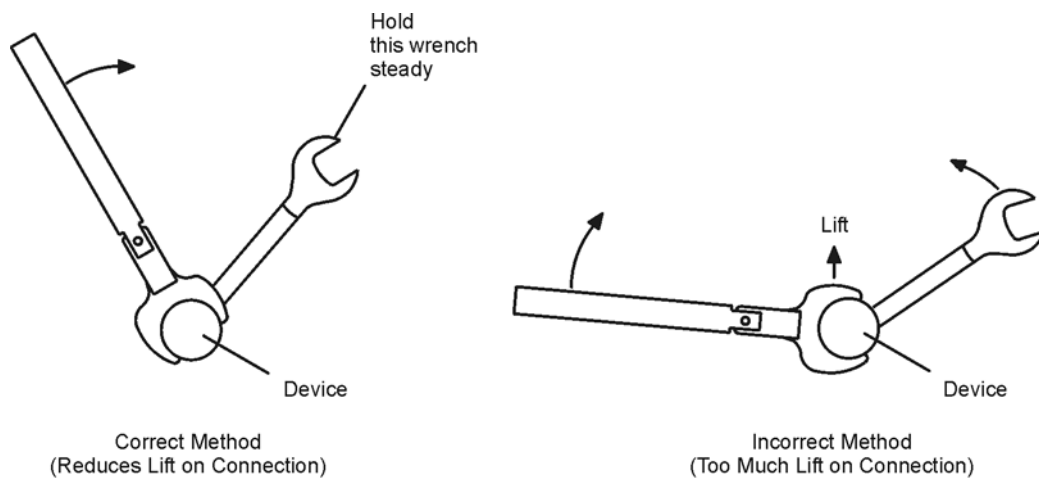

ph711a

2. Hold the torque wrench lightly, at the end of the handle only (beyond the groove). See [Figure 4-8](#).

**Figure 4-8 Using the Torque Wrench**

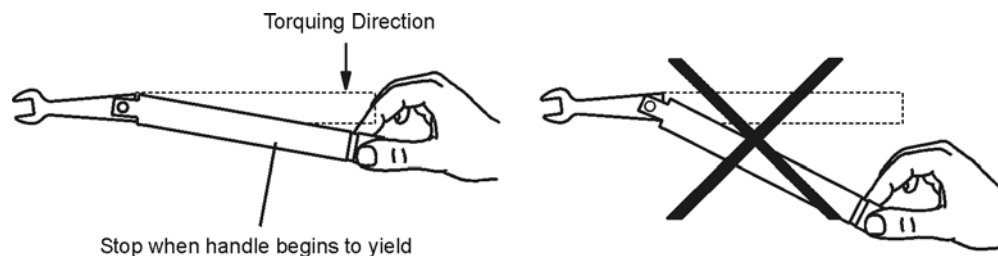

ph712a

3. Apply downward force perpendicular to the wrench handle. This applies torque to the connection through the wrench.

Do not hold the wrench so tightly that you push the handle straight down along its length rather than pivoting it, otherwise you apply an unknown amount of torque.

---

**CAUTION** You don't have to fully break the handle of the torque wrench to reach the specified torque; doing so can cause the handle to kick back and loosen the connection. Any give at all in the handle is sufficient torque.

---

4. Tighten the connection just to the torque wrench break point. The wrench handle gives way at its internal pivot point. See [Figure 4-8](#). Do not tighten the connection further.

## Connecting the Airline

---

**CAUTION** Before making any connections to the test set, be sure that bias power to the test set is off, and take care to avoid electrostatic discharge. Refer to [“Electrostatic Discharge”](#) on page 4-2.

---

**CAUTION** Wear gloves while performing the following procedure. You will be touching the exposed center conductor of the airline. It is important that you do not transfer oil and dirt from your fingers to this center conductors. Refer to [“Handling and Storage”](#) on page 4-18.

---

Before making the connection, refer to [“Preliminary Connection”](#) on page 4-14.

Cables with the appropriate adapters on the ends should be connected to PORT 1 and PORT 2 of the network analyzer.

1. Remove the center conductor from its plastic case. Make sure you select the correct center conductor for the airline you are connecting. Refer to [Figure 2-3](#) and [Figure 2-4](#) on page 2-5 for illustrations of both center conductors.
2. Remove the protective end cap from the female end (the end without the connecting nut) of the airline.
3. Leave the protective end cap on the male end of the airline to prevent the center conductor from falling out of the outer conductor.

**Figure 4-9 Airline Center Conductor Placement**

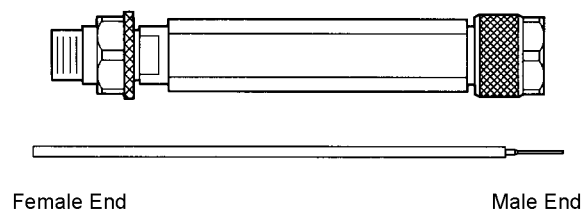

f41

4. Insert the female end of the center conductor into the outer conductor so that the female end of the center conductor is toward the female end of the outer conductor (the end without the connector nut). Refer to [Figure 4-9](#).

---

**NOTE** To avoid damaging the airline center conductor, always keep it in direct line with the center conductor of the device to which it is being connected.

---

5. Bring the airline—with center conductor installed—toward the cable connector and mate the female end of the airline center conductor with the center conductor of the cable connector. Refer to [Figure 4-10](#).

**Figure 4-10 Connecting the Airline**

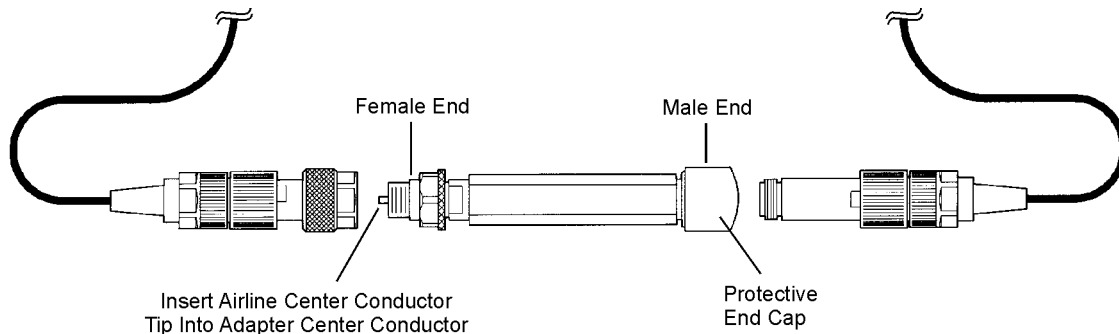

f43

6. Push the airline's female coupling sleeve forward and turn the connecting nut (of the adapter attached to the cable) to mate the outer conductor of the airline with the adapter. Connect the nut finger tight. Do not overtighten.
7. Remove the protective end cap from the male end of the airline. Align and insert the male end of the airline center conductor into the female end of the cable adapter and mate the outer conductors. Connect the nut finger tight. Do not overtighten.
8. Using an open-end wrench, hold the sliding female coupling sleeve on the female end of the outer conductor to keep it from rotating. Refer to [Figure 4-11](#). Use the torque wrench recommended for use with this kit to tighten the adapter connecting nut to the specified torque. Refer to [“Final Connection Using a Torque Wrench”](#) on page 4-14.
9. Using an open-end wrench to keep the cable adapter from rotating, use the torque wrench recommended for use with this kit to tighten the airline male-end connecting nut to the specified torque.

**Figure 4-11 Torquing the Connections**

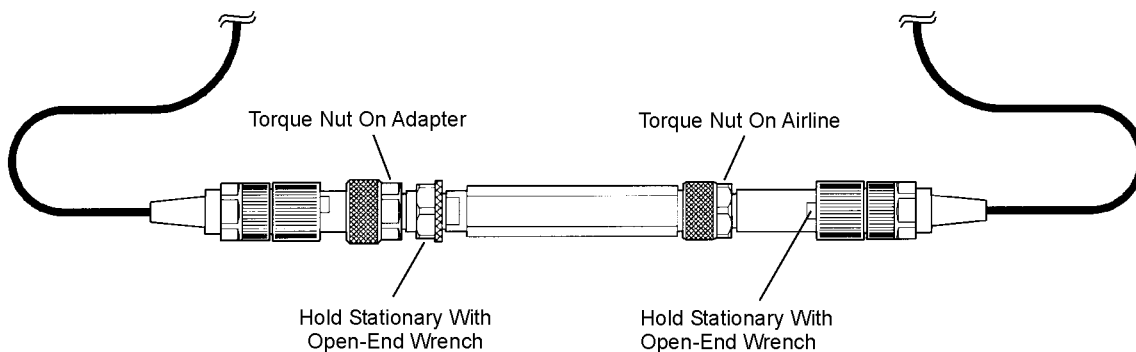

f44

## How to Separate a Connection

---

**NOTE** Do *not* turn the device body. Only turn the connector nut. Damage to the center conductor can occur if the device body is rotated.

---

1. Use an open-end wrench to prevent the device body from turning.
2. Use the torque wrench to loosen the connector nut.
3. Complete the disconnection by hand, turning only the connector nut.
4. Pull the connectors straight apart without twisting, rocking, or bending either of the connectors.

---

**NOTE** If disconnecting an airline and the airline center conductor does not disengage from the device center conductor, gently pull the center conductors apart and then push the airline center conductor back inside the outer conductor of the airline.

---

---

## Handling and Storage

- Do install the protective end caps and store the devices in the foam-lined storage case when not in use.
- Do keep connectors and airlines clean.
- Do *not* touch mating plane surfaces. Natural skin oils and microscopic particles of dirt are easily transferred to a connector interface and are very difficult to remove.
- Do *not* store connectors and airlines loose in a box, or in a desk or bench drawer. This is the most common cause of connector damage during storage.
- Do *not* set connectors contact-end down on a hard surface. The plating and the mating plane surfaces can be damaged if the interface comes in contact with any hard surface.



# **5 Performance Verification**

## Introduction

The performance of your verification kit can only be verified by returning the kit to Agilent Technologies for recertification. The equipment required to verify the specifications of the devices in the kit has been specially manufactured and is not commercially available.

---

## How Agilent Verifies the Devices in Your Kit

Agilent verifies the specifications of these devices as follows:

1. The residual microwave error terms of the test system are verified with precision airlines and shorts that are directly traced to the National Institute of Standards and Technology (NIST). The airline and short characteristics are developed from mechanical measurements. The mechanical measurements and material properties are carefully modeled to give very accurate electrical representation. The mechanical measurements are then traced to NIST through various plug and ring gages and other mechanical measurements.
2. Each device is electrically tested on this system. For the initial (before sale) testing of the devices, Agilent includes the test measurement uncertainty as a guardband to guarantee each device meets the published specification. For recertifications (after sale), no guardband is used and the measured data is compared directly with the specification to determine the pass or fail status. The measurement uncertainty for each device is, however, recorded in the calibration report that accompanies recertified kits.

These two steps establish a traceable link to NIST for Agilent to the extent allowed by the institute's calibration facility. The specifications data provided for the devices in the kit is traceable to NIST through Agilent Technologies.

---

## Recertification

The following will be provided with a recertified kit:

- a new calibration sticker affixed to the case
- a certificate of calibration
- a calibration report for each device in the kit listing measured values, specifications, and uncertainties

---

**NOTE** A list of NIST traceable numbers may be purchased upon request to be included in the calibration report.

---

Agilent Technologies offers a *Standard*, an *ISO 17025*, and an *ANSI Z540* calibration for the recertification of the kit. For more information, contact Agilent Technologies. See [“Contacting Agilent” on page 6-5](#).

### How Often to Recertify

The suggested initial interval for recertification is 12 months or sooner. The actual need for recertification depends on the use of the kit. After reviewing the results of the initial recertification, you may establish a different recertification interval that reflects the usage and wear of the kit.

---

**NOTE** The recertification interval should begin on the date the kit is *first used* after the recertification date.

---

### Where to Send a Kit for Recertification

Contact Agilent Technologies for information on where to send your kit for recertification. See [“Contacting Agilent” on page 6-5](#). Refer to [“Returning a Kit or Device to Agilent Technologies” on page 6-4](#) for details on sending your kit.



## **6 Troubleshooting**

## Troubleshooting Process

If your network analyzer does not pass performance verification, follow the steps in [Figure 6-1](#) to determine the cause of the failure and the correct action to take to correct the failure.

---

## Compatible Network Analyzers

The devices in this kit and their data are compatible with the following network analyzers:

- 8510 Series
- 8719 Series and 8720 Series
- PNA Series

The data disk provided for use with each of the above listed network analyzers contains the factory-measured S-parameter data for the devices in this kit. It also contains the uncertainty limits used in the system verification procedure. This data is unique to each kit.

It is recommended that a backup copy of the data disk and data printout be made immediately upon receipt of the verification disk. Refer to [Chapter 3](#) , “[Duplicating Your Verification Data](#),” for instructions.

Figure 6-1 Troubleshooting Flowchart

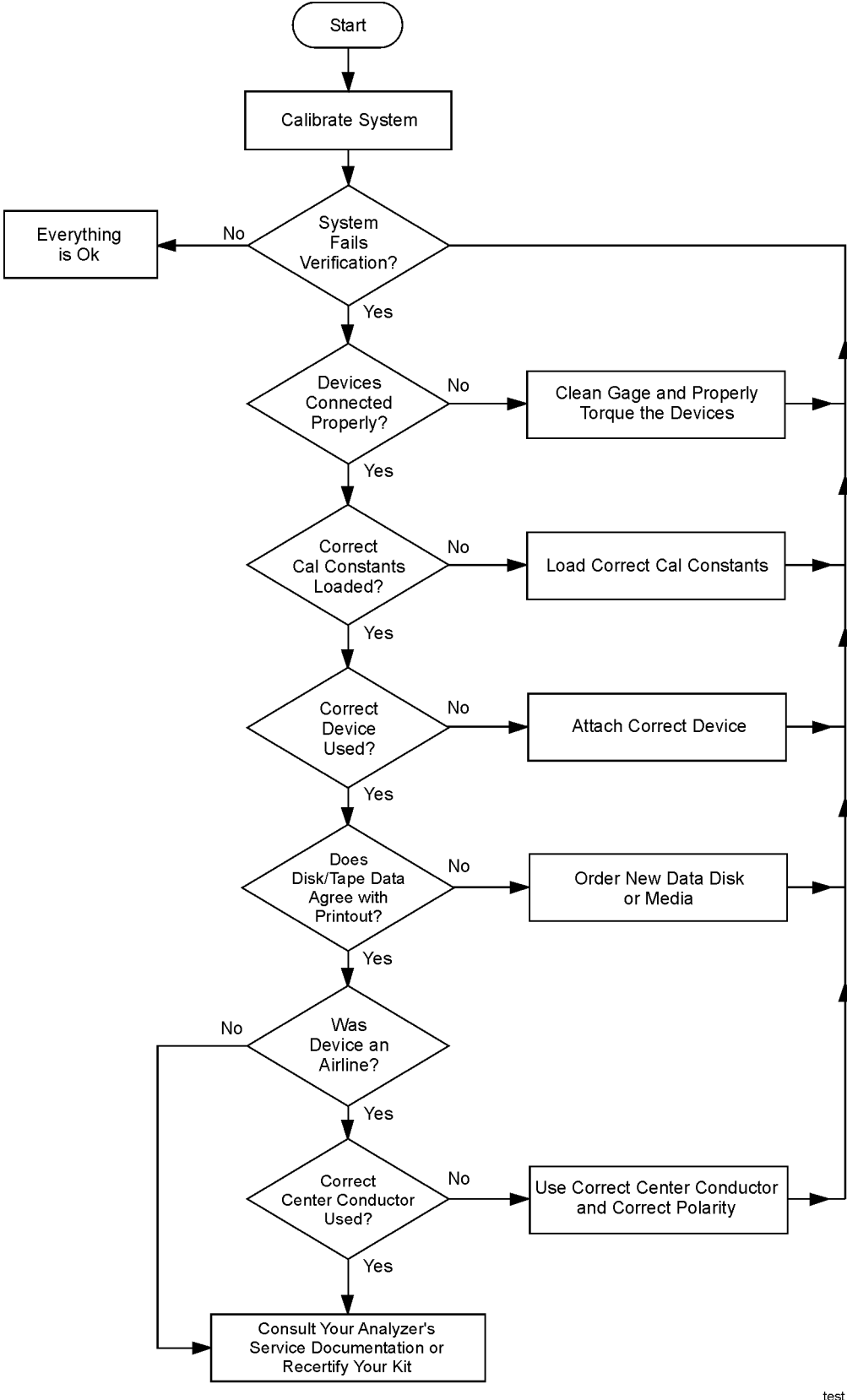

## Where to Look for More Information

This manual contains limited information about network analyzer system operation. For detailed information on using a VNA, ENA or PNA series network analyzer, refer to the appropriate user guide or online Help.

- To view the ENA or PNA online Help, press the Help key on the front panel of the network analyzer.
- To view an online VNA user guide, use the following steps:
  1. Go to *www.agilent.com*.
  2. Enter your VNA model number (Ex: 8753ES) in the Search box and click **Search**.
  3. Under the heading **Manuals & Guides**, click on the title/hyperlink for the document PDF you want to view.

If you need additional information, see “Contacting Agilent” on page 5.

---

## Returning a Kit or Device to Agilent Technologies

If your kit or device requires service, contact Agilent Technologies for information on where to send it. See “[Contacting Agilent](#)” on page 6-5. Include a service tag (located at the back of this manual) on which you provide the following information:

- your company name and address.
- a technical contact person within your company, and the person's complete phone number including the country code and area code.
- the model number and serial number of the kit (if returning a complete kit)
- the part number and serial number of each device being returned
- the type of service required
- a *detailed* description of the problem (if applicable) and how the device was being used when the problem occurred.



---

## Contacting Agilent

Assistance with test and measurements needs and information on finding a local Agilent office are available on the Web at:

[www.agilent.com/find/assist](http://www.agilent.com/find/assist)

If you do not have access to the Internet, please contact your Agilent field engineer.

---

**NOTE**      In any correspondence or telephone conversation, refer to the Agilent product by its model number and full serial number. With this information, the Agilent representative can determine whether your product is still within its warranty period.

---



## **7 Replaceable Parts**

## Introduction

Table 7-1 lists the replacement part numbers for items included in the 85055A verification kit and Figure 7-1 illustrates these items.

Table 7-2 lists the replacement part numbers for items not included in the verification kit that are either required or recommended for successful operation of the kit.

To order a listed part, note the description, the part number, and the quantity desired. Telephone or send your order to Agilent Technologies. See “Contacting Agilent” on page 6-5.

**Table 7-1 Replaceable Parts for the 85055A 50Ω Type-N Verification Kit**

Description	Qty Per Kit	Agilent Part Number
<b>Attenuators (50Ω Type-N)</b>		
20 dB attenuator with data	1	85055-60003
50 dB attenuator with data	1	85055-60004
<b>Airlines (Type-N)</b>		
50Ω airline with data	1	85055-60006
25Ω mismatch airline with data	1	85055-60007
<b>Wrench</b>		
1/2 in and 9/16 in open-end wrench	1	8710-1770
<b>Verification Kit Storage Case</b>		
Box (without foam pads)	1	5180-7899
Foam pad (for lid)	1	5180-8490
Foam pad (for lower case)	1	85055-80011
<b>User's and Service Guide</b>		
User's and service guide <sup>a</sup>	1	85055-90014
<b>Verification Data Media</b>		
Verification data disk for 8510C analyzer	1	85055-10003
Verification data disk for 8719 series and 8720 series analyzers	1	85055-10002
Verification data disk for PNA series analyzers	1	85055-10012

a. See “Printing Copies of Documentation from the Web” on page ii.

**Table 7-2 Items Not Included in the Verification Kit**

Description	Qty	Agilent Part Number
<b>Connector Gages (50Ω Type-N)</b>		
Connector gage set <sup>a</sup> (includes the items listed below)	1	85054-60049
Female gage	1	85054-60050
Female gage master	1	85054-60052
Male gage	1	85054-60051
Male gage master	1	85054-60053
Centering bead (two supplied with the gage set)	1	85054-80028
<b>Short (50Ω Type-N)</b>		
Male short (for gaging airlines) <sup>a</sup>	1	85054-60025
Male short (for gaging airlines) <sup>b</sup>	1	85032-60016
<b>Wrenches</b>		
3/4 in, 135 N-cm (12 in-lb) torque wrench	1	8710-1766
<b>ESD Protection Devices</b>		
Grounding wrist strap	1	9300-1367
5 ft grounding cord for wrist strap	1	9300-0980
2 x 4 ft conductive table mat and 15 ft ground wire	1	9300-0797
<b>Connector Cleaning Supplies</b>		
Anhydrous isopropyl alcohol (>92% pure) <sup>c</sup>	--	--
Cleaning swabs	100	9301-1243

a. Included in the 85054B type-N calibration kit.

b. Included in the 85032F type-N calibration kit.

c. Agilent can no longer safely ship isopropyl alcohol, so customers should purchase it locally.

**Figure 7-1 Replaceable Parts for the 85055A 50Ω Type-N Verification Kit**

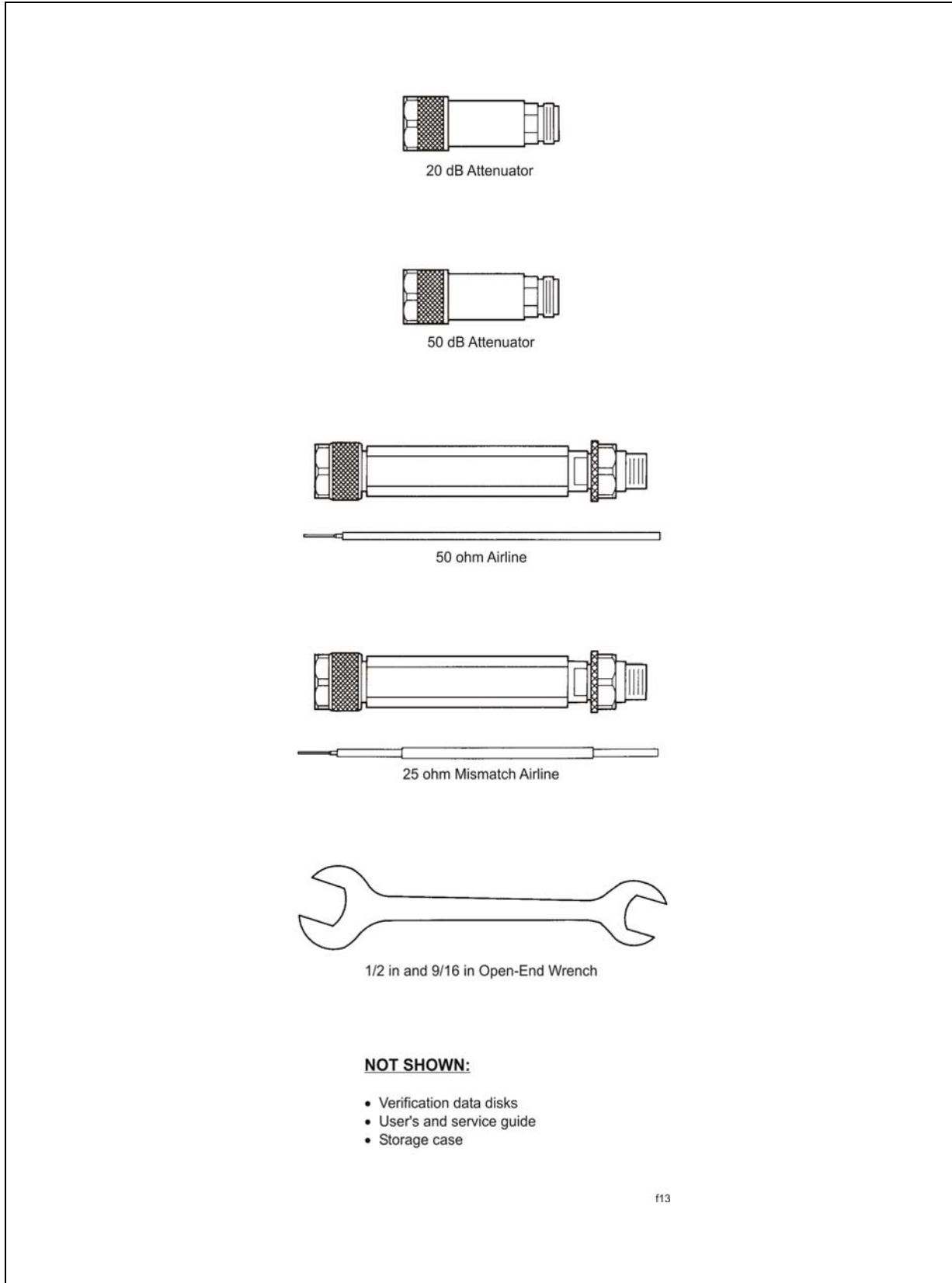

## A

Agilent Technologies  
  contacting, 6-4, 6-5  
airline  
  assembling, 4-11, 4-16  
  attaching the short, 4-11  
  connecting, 4-16  
  dimensions, 2-4  
    center conductor, 2-5  
    outer conductor, 2-5  
  disconnecting, 4-18  
  gaging, 4-10, 4-12  
  mechanical characteristics, 2-4  
  mismatch, 2-5  
  part numbers, 7-2  
alcohol  
  isopropyl  
    as cleaning solvent, 4-5  
    precautions for use of, 4-5  
altitude  
  specifications, 2-2  
ANSI Z540, calibration, 5-3  
attenuators  
  part numbers, 7-2

## B

bead  
  centering  
    part number, 7-3  
box  
  pads  
    part numbers, 7-2  
  part number, 7-2

## C

calibration  
  ANSI Z540, 5-3  
  bad, 6-2  
  certificate of, 5-3  
  ISO 17025, 5-3  
  kit  
    intended to be used, 1-2  
  report, 5-3  
  temperature, 2-2  
case  
  storage  
    part number, 7-2  
center conductor  
  protrusion, 4-7  
  recession, 4-7  
centering bead  
  part number, 7-3  
certificate of calibration, 5-3  
characteristics  
  mechanical, 2-3  
  supplemental, 2-3

cleaning connectors, 4-4  
compatibility  
  with analyzers, 6-2  
compressed air or nitrogen, 4-4  
conductive table mat  
  part number, 7-3  
conductor  
  mating plane, 2-3  
  protrusion, 2-3  
  recession, 2-3  
  conductor  
    recession, 2-3  
connections, 4-2, 4-14  
  airline, 4-16  
  ESD protection, 4-14  
  final, 4-14  
  preliminary, 4-14  
  separating, 4-18  
  using torque wrench, 4-14  
connector  
  cleaning, 4-4  
  conventional, 1-5, 4-4  
  damage, 4-3  
  defects, 4-3  
  female, 1-5, 4-4  
  gage  
    accuracy, 4-6  
    dial, 4-7  
    handling, 4-6, 4-8, 4-10  
    master, 4-8  
    part numbers, 7-3  
    reading, 4-7  
    use of, 4-6  
    zeroing, 4-6, 4-8, 4-10  
  gaging, 4-6, 4-8  
    to determine pin depth, 4-6  
    when to do, 4-6  
  gender, 1-6  
  male  
    gaging, 4-8  
  mating plane surfaces, 2-3, 4-5  
  cleaning, 4-5  
  slotless, 1-5, 4-4  
    accuracy, 1-5, 4-4  
    characteristics, 1-5  
  slotted, 1-5, 4-4  
    accuracy, 1-5, 4-4  
  threads  
    cleaning, 4-5  
    inspecting, 4-3  
  visual inspection, 4-3  
  wear, 4-3  
    affect on electrical  
      performance, 4-3  
contacting Agilent Technologies,  
  6-4  
contents

drawing of, 7-4  
  verification kit, 7-4  
copying verification data disks,  
  3-2  
cord  
  grounding  
    part number, 7-3

## D

damage  
  device, 4-3  
  inspecting for, 1-3, 4-3  
  to connectors, 4-3  
  what to do, 1-3  
damaged connectors, 4-3  
data  
  recertification, 5-3  
data disk  
  duplicating  
    8510C, 3-3  
    872x Series, 3-4  
    PNA Series, 3-5  
  verification  
    part number, 7-2  
data tape  
  verification  
    part number, 7-2  
defective connectors, 4-3  
defects  
  connector, 4-3  
device  
  compatibility  
    with analyzers, 6-2  
  conductor  
    mating plane, 2-3  
  connecting, 4-14  
  damage, 4-3  
  disconnecting, 4-18  
  handling, 4-18  
  maintenance, 1-6  
  performance  
    verifying, 5-2  
  pin depth, 2-3  
  specifications, 2-6  
  traceability, 5-2, 5-3  
  storage, 4-18  
  temperature, 2-2  
  visual inspection, 4-3  
dial  
  connector gage, 4-7  
dimensions  
  airline, 2-4  
    center conductor, 2-5  
    outer conductor, 2-5  
device  
  center conductor, 2-3  
  outer conductor, 2-3

- disconnections, 4-18
- disk
  - duplicating
    - 8510C, 3-3
    - 872x Series, 3-4
    - PNA Series, 3-5
  - verification data
    - part number, 7-2
- duplicating
  - verification data disk
    - 8510C, 3-3
  - verification disk
    - 872x Series, 3-4
    - PNA Series, 3-5
- E**
- electrical specifications, 2-6
- electrostatic discharge, 4-2
- environmental
  - regulations, 4-5
  - requirements, 2-2
  - specifications, 2-2
- equipment required, 1-2
- ESD, 4-2
  - precautions, 4-2, 4-4
  - supplies
    - part numbers, 7-3
- F**
- female connectors, 4-4
- inspection of, 4-4
- flowchart
  - troubleshooting, 6-3
- frequency range, 1-2
- G**
- gage
  - connector
    - dial, 4-7
    - handling, 4-8, 4-10
    - master, 4-8
    - part numbers, 7-3
    - reading, 4-7
    - zeroing, 4-8
    - zeroing using short, 4-10
  - gage master
    - part numbers, 7-3
    - using, 4-8
  - gaging
    - airline, 4-10, 4-12
    - connectors, 4-6, 4-8
      - when to do, 4-6
    - male connectors, 4-8
    - procedures, 4-8
    - to determine pin depth, 4-6
  - gender, connector, 1-6
- grounding cord
  - part number, 7-3
- H**
- handling, 4-18
- humidity
  - specifications, 2-2
- I**
- incoming inspection, 1-3
- information, troubleshooting, 6-4
- inspection
  - damage, 4-3
  - defects, 4-3
  - female connectors, 4-4
  - incoming, 1-3
  - mating plane surfaces, 4-3
  - visual, 4-3
- ISO 17025, calibration, 5-3
- isopropyl alcohol
  - as cleaning solvent, 4-5
  - precautions for use of, 4-5
- K**
- kit
  - calibration
    - intended to be used, 1-2
  - contents, 1-2, 7-4
  - drawing of, 7-4
  - frequency range, 1-2
  - overview, 1-2
  - performance
    - how Agilent verifies, 5-2
    - verifying, 5-2
- M**
- maintenance, 4-2
  - of devices, 1-6
  - preventive, 1-6
- making connections, 4-14
  - ESD protection, 4-14
  - precautions, 4-14
- manual
  - copyright dates, 1-i
  - part number, 1-i, 7-2
  - print date, 1-i
  - title, 1-i
- mat
  - conductive
    - part number, 7-3
- mating plane
  - conductor, 2-3
  - surfaces
    - cleaning, 4-5
    - connector, 4-5
    - inspection of, 4-3
- mechanical characteristics, 2-3
  - verifying, 4-6
- mechanical integrity, 2-3
- mismatch airline, 2-5
- N**
- National Institute of Standards and Technology (NIST), 2-6, 5-2
- nitrogen, 4-4
- numbers
  - replaceable parts, 7-2
  - serial
    - recording, 1-4
- O**
- open-end
  - wrench
    - part number, 7-3
- open-end wrench, 4-18
- ordering parts, 7-2
- P**
- part numbers, 7-2
  - of items in kit, 7-2
  - of items not in kit, 7-3
- parts
  - included in kit, 7-2
  - not included in kit, 7-2, 7-3
  - ordering, 7-2
  - replaceable, 7-2
- performance verification
  - fail, 6-2
- pin depth, 2-3
  - definition of, 2-3
  - effect on electrical
    - specifications, 2-4
  - gaging to determine, 4-6
  - importance of, 2-4
  - observed limits, 4-6
  - specifications, 2-4
- precision slotless connector (PSC), 1-5, 4-4
- preventive maintenance, 1-6
- protrusion
  - center conductor, 4-7
  - conductor, 2-3
- protrusion, pin depth, 2-3
- R**
- reading connector gage, 4-7
- recertification
  - how to order, 5-3
  - interval, 5-3
  - what's included, 5-3
  - where it's done, 5-3



recession  
  center conductor, 4-7  
  conductor, 2-3  
recession, pin depth, 2-3  
regulations  
  environmental, 4-5  
replaceable parts, 7-2, 7-4  
  drawing of, 7-4  
report, calibration, 5-3  
requirements  
  environmental, 2-2  
return  
  kit or device to Agilent, 6-4

**S**

separating connections, 4-18  
serial numbers  
  devices, 1-4  
  recording, 1-4  
service, 6-4  
service tag, 6-4  
shipment  
  verifying complete, 1-3  
short  
  attaching to airline, 4-11  
  part number, 7-3  
  using to zero gage, 4-10  
slotless connector, 1-5, 4-4  
  accuracy, 1-5, 4-4  
  characteristics, 1-5  
slotted connector, 1-5, 4-4  
  accuracy, 1-5, 4-4  
specifications, 2-2  
  altitude  
    operating, 2-2  
    storage, 2-2  
  device, 2-6  
  electrical, 2-6  
  environmental, 2-2  
  humidity, 2-2  
  pin depth, 2-4  
  temperature, 2-2  
  torque wrench, 4-14  
  traceability, 5-2, 5-3  
standards  
  National Institute of Standards  
  and Technology (NIST), 5-2  
static discharge, 4-2  
storage, 4-18  
storage case  
  part number, 7-2  
strap  
  wrist  
    part number, 7-3  
supplemental characteristics, 2-3

**T**

tag, service, 6-4  
tape  
  verification data  
    part number, 7-2  
temperature  
  affect on electrical performance,  
    2-2  
  calibration, 2-2  
  cautions about, 2-2  
  changes in, 2-2  
  device, 2-2  
  error-corrected, 2-2  
  measurement, 2-2  
  specifications, 2-2  
    operating, 2-2  
    storage, 2-2  
  verification and measurement,  
    2-2  
test data, 5-3  
threads  
  connector  
    cleaning, 4-5  
    inspecting, 4-3  
torque wrench  
  part number, 7-3  
  specifications, 4-14  
traceability  
  of device specifications, 5-2, 5-3  
troubleshooting, 6-2  
  flowchart, 6-3

**U**

user's and service guide  
  part number, 7-2

**V**

verification  
  temperature, 2-2  
verification data disk  
  duplicating  
    8510C, 3-3  
    872x Series, 3-4  
    PNA Series, 3-5  
  part number, 7-2  
verification data tape  
  part number, 7-2  
verification kit  
  contents, 1-2, 7-4  
  drawing of, 7-4  
  frequency range, 1-2  
  overview, 1-2  
  performance  
    how Agilent verifies, 5-2  
    verifying, 5-2  
  visual inspection, 4-3

**W**

wear  
  connector, 4-3  
    affect on electrical  
    performance, 4-3  
wrench  
  open-end, 4-15, 4-18  
  part number, 7-2, 7-3  
  proper positioning of, 4-15  
  torque, 4-14, 4-15  
  part number, 7-3  
  precautions for use of, 4-15  
  proper use of, 4-15  
wrist strap  
  part number, 7-3

**Z**

zeroing  
  connector gage, 4-8  
  using short, 4-10

